

BIRD

Edwin
Corrie

1

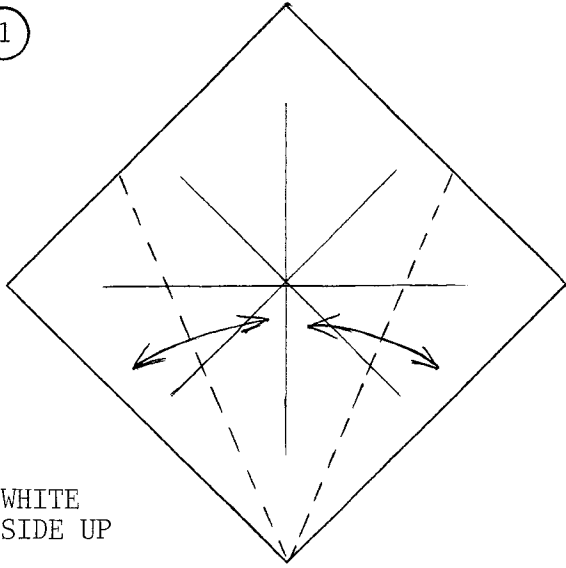

WHITE
SIDE UP

2

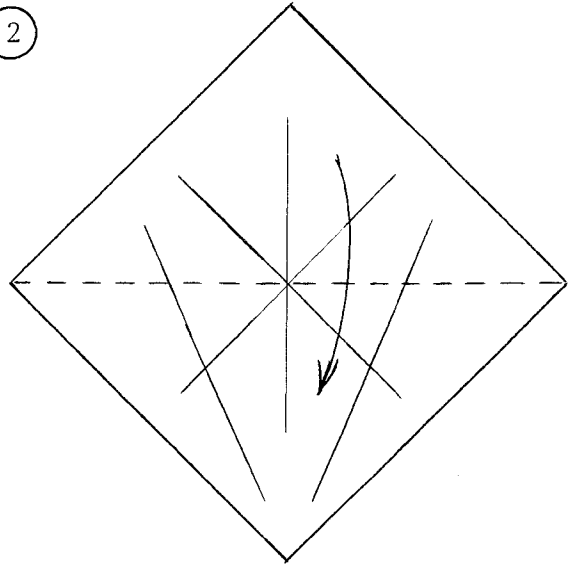

3

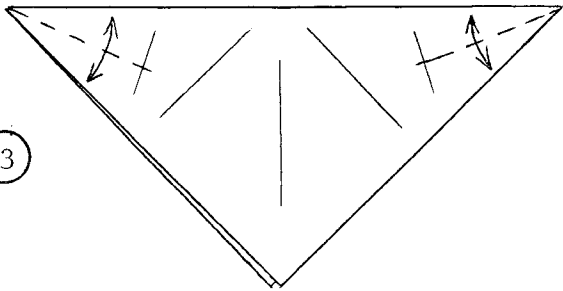

4

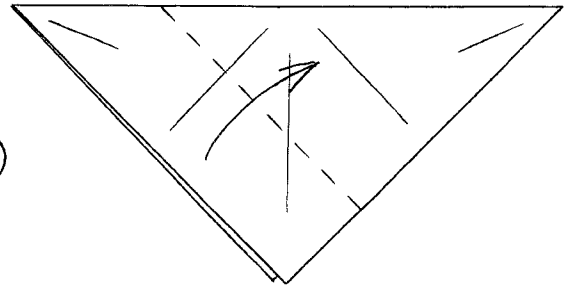

5

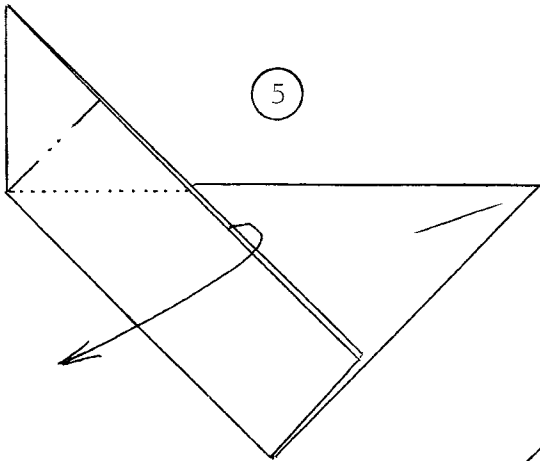

6

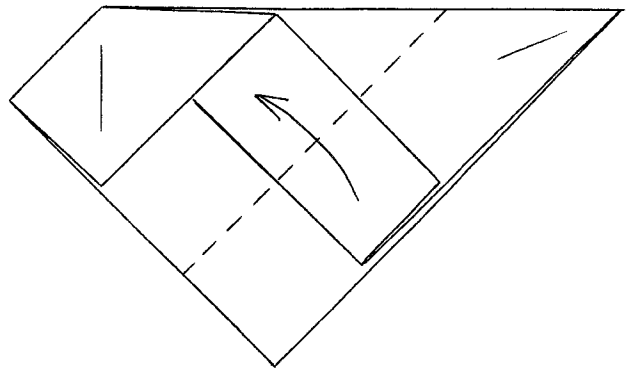

7

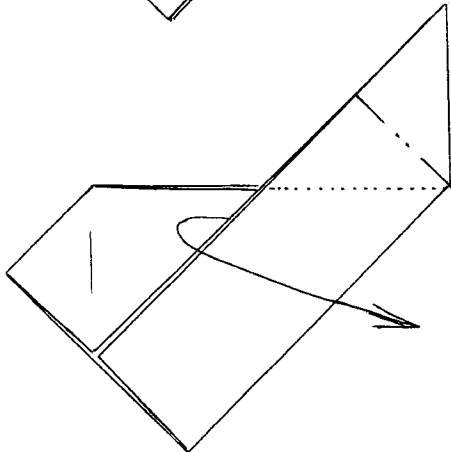

8

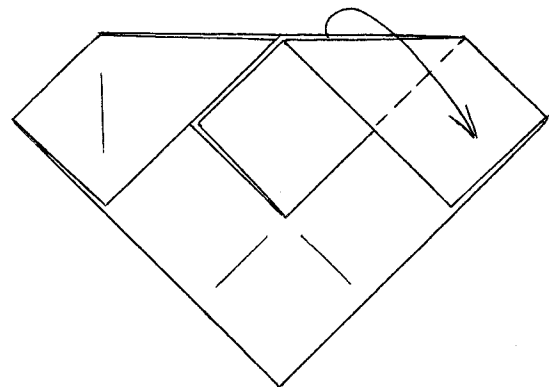

9

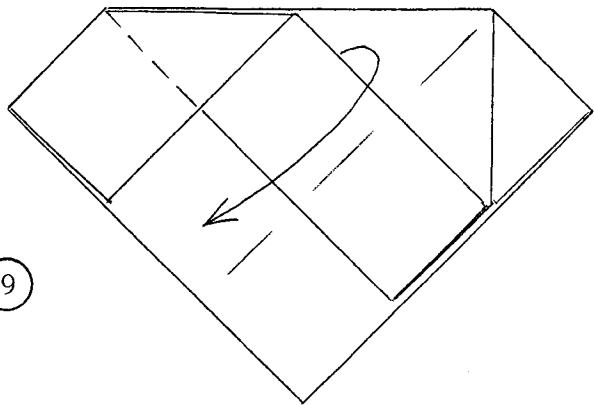

10

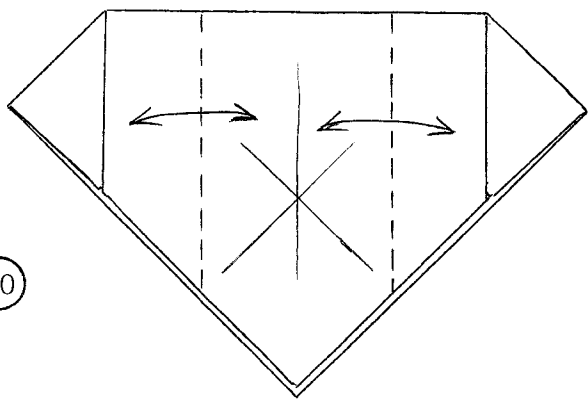

11

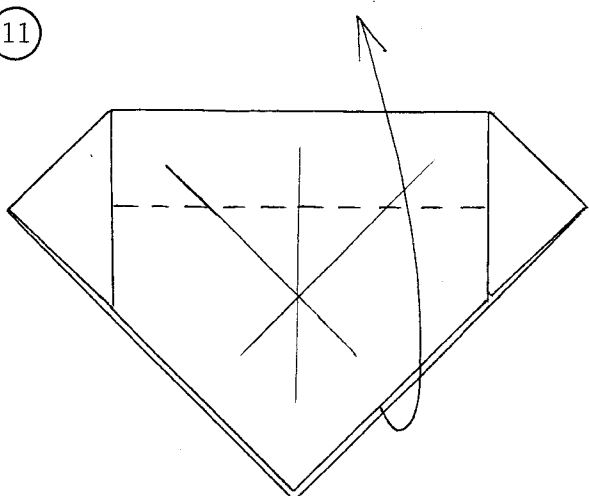

12

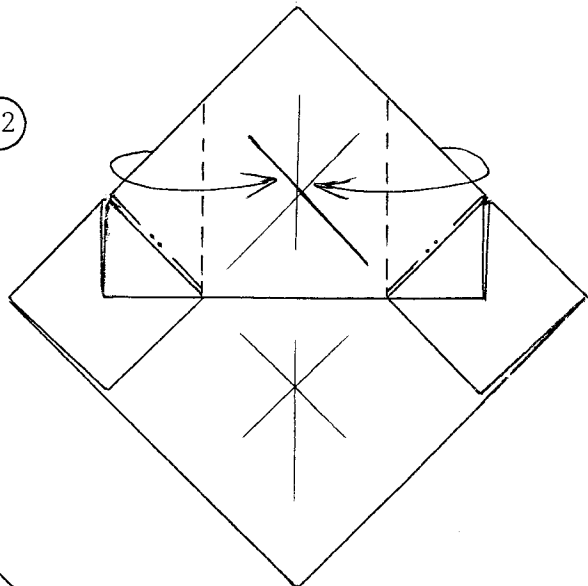

13

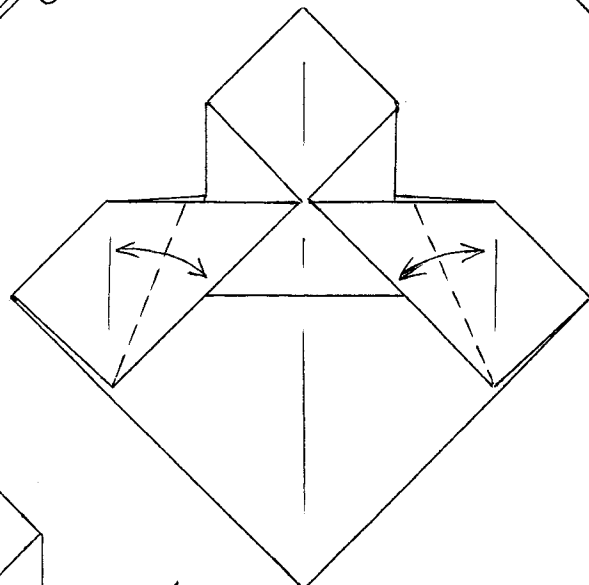

14

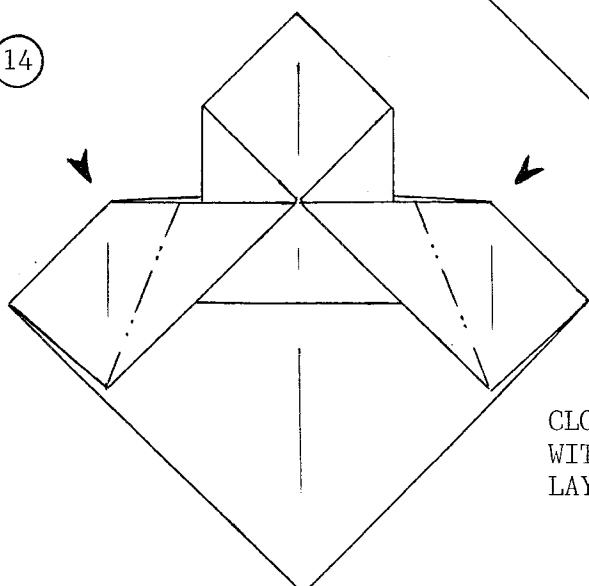

15

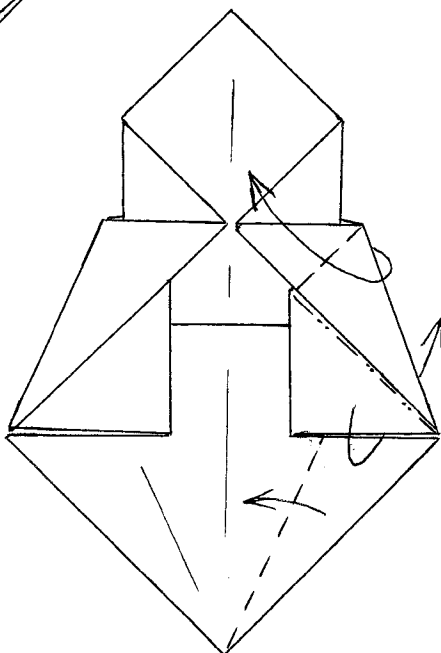

CLOSED SINKS
WITH A SINGLE
LAYER ON TOP

16

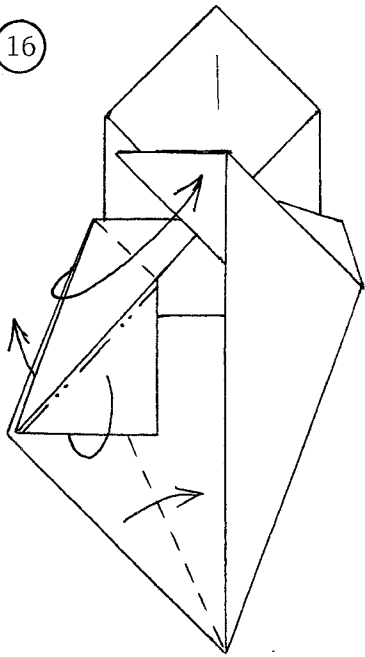

17

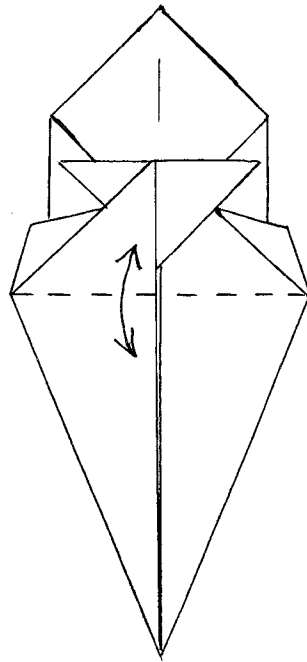

18

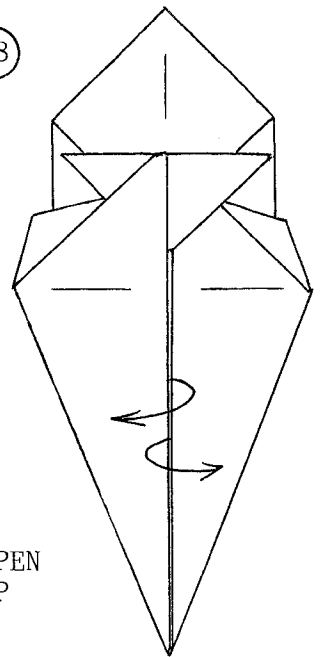

OPEN UP

19

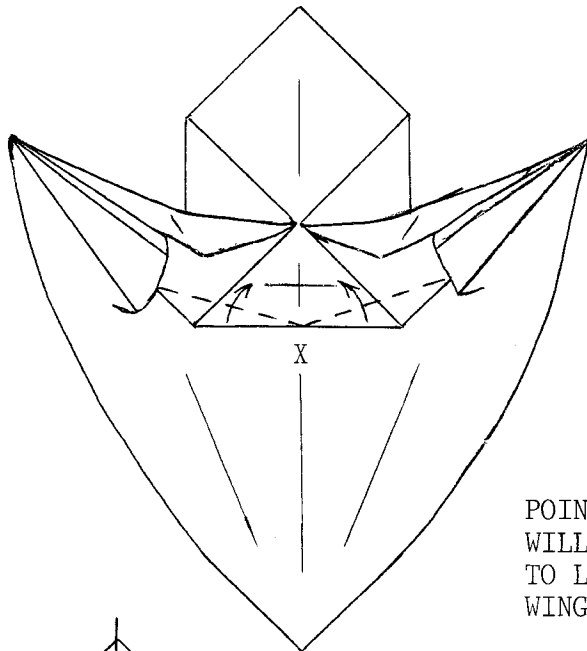

20

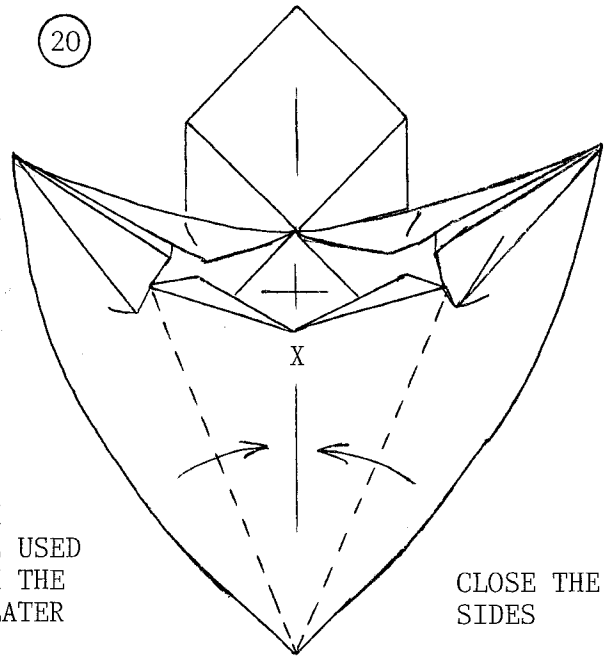

POINT X
WILL BE USED
TO LOCK THE
WINGS LATER

CLOSE THE
SIDES

21

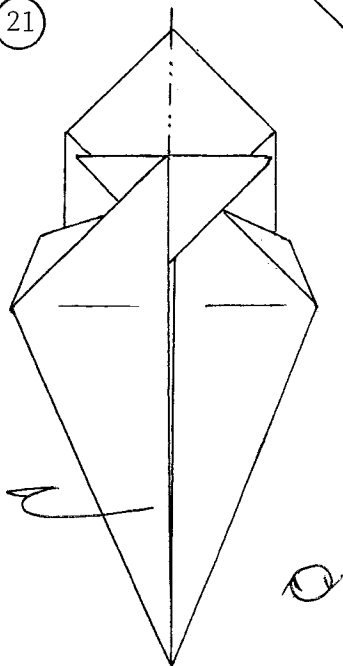

22

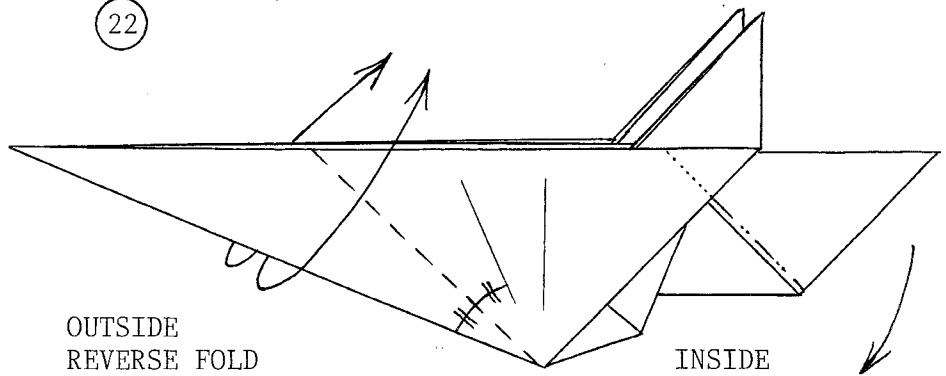

OUTSIDE
REVERSE FOLD

INSIDE
REVERSE FOLD

23

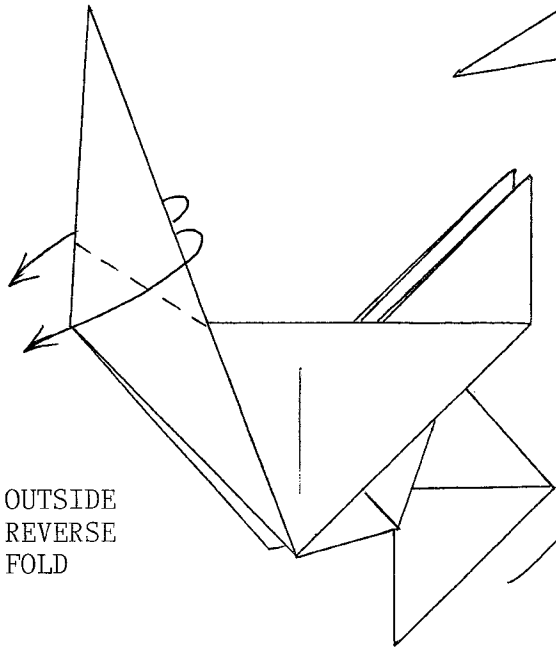

OUTSIDE
REVERSE
FOLD

24

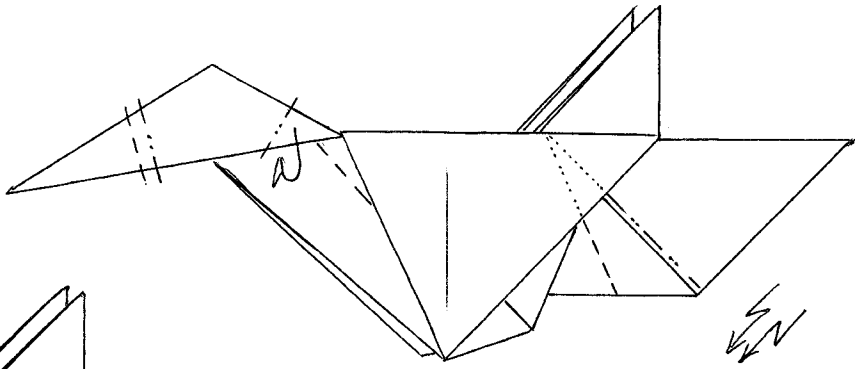

CRIMP

UNDO

25

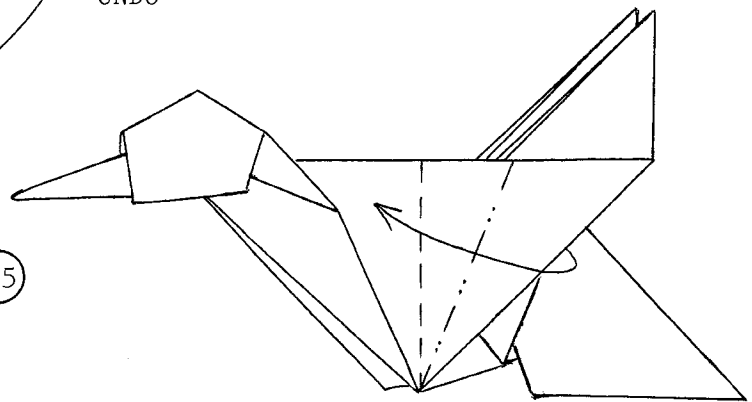

26

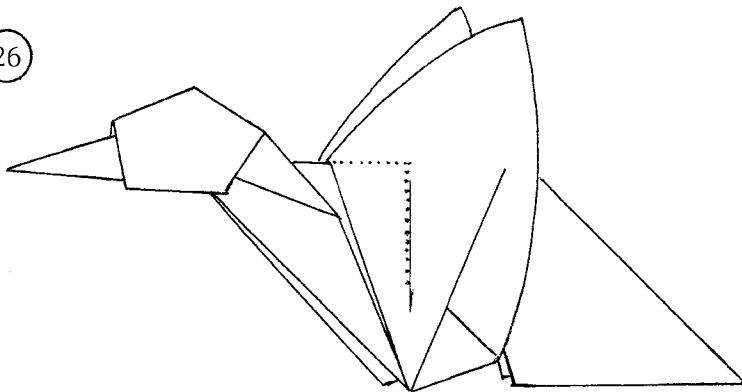

SQUASH FOLD
THE TOP LAYER,

THE VERTICAL CREASE
WAS MADE IN STEP 17.

OPEN THE MODEL
AND TUCK THE HIDDEN FLAPS
UNDER POINT X AS IDENTIFIED
IN STEPS 19 AND 20.

27

