

HEART BOX

Edwin
Corrie

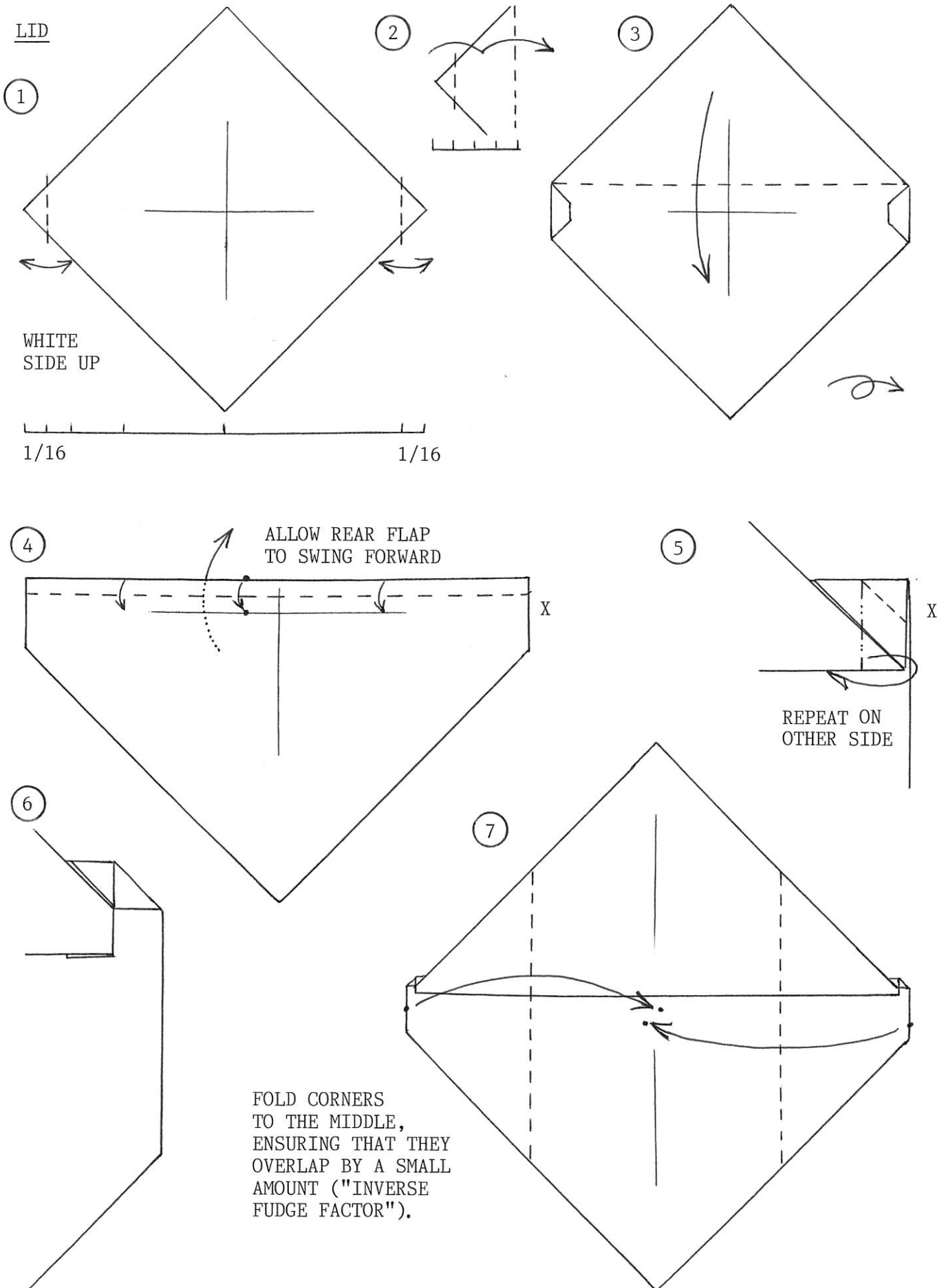

8

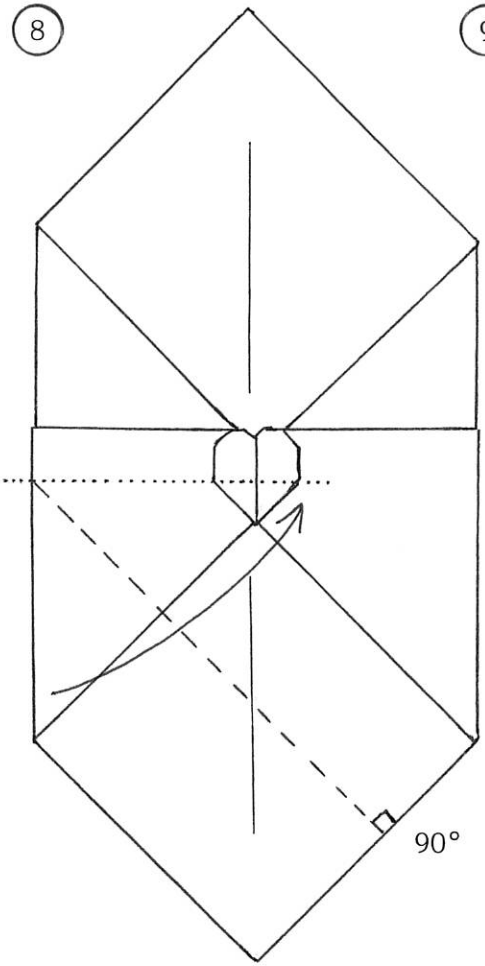

9

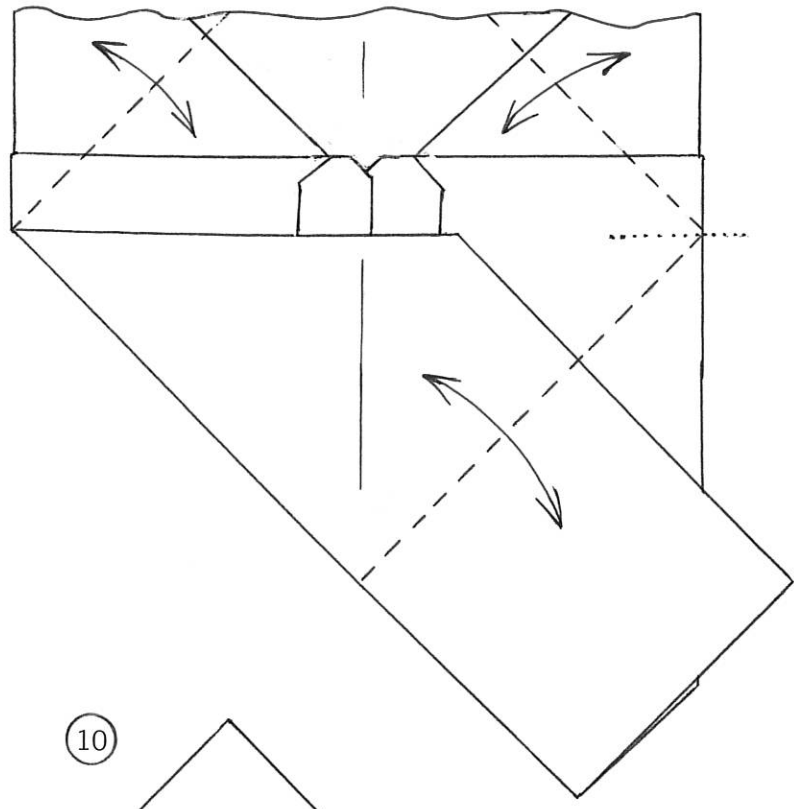

10

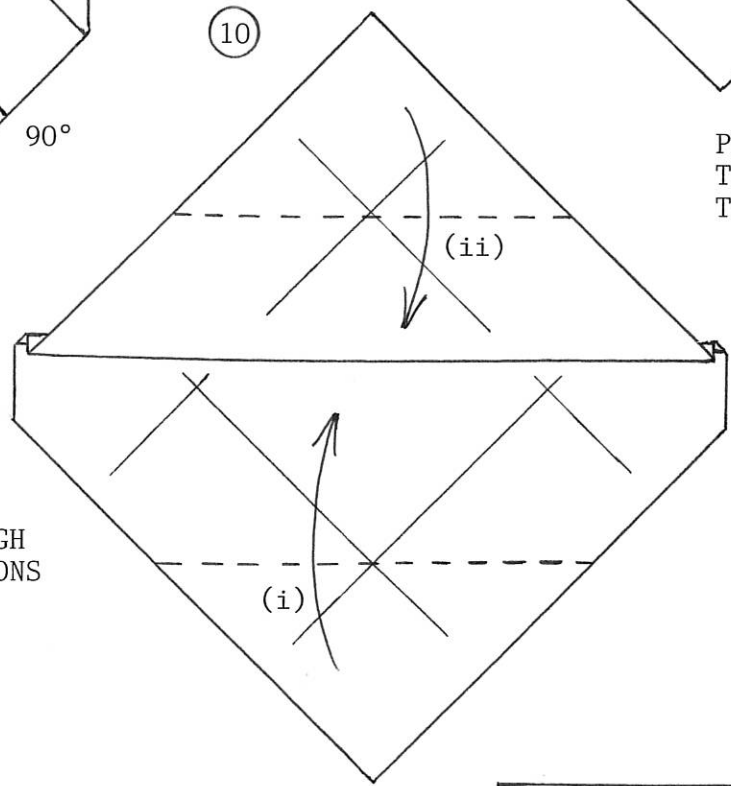

PRECREASE,
THEN UNFOLD
TO STEP 7.

VALLEY FOLD THROUGH
CREASE INTERSECTIONS
AS SHOWN.

11

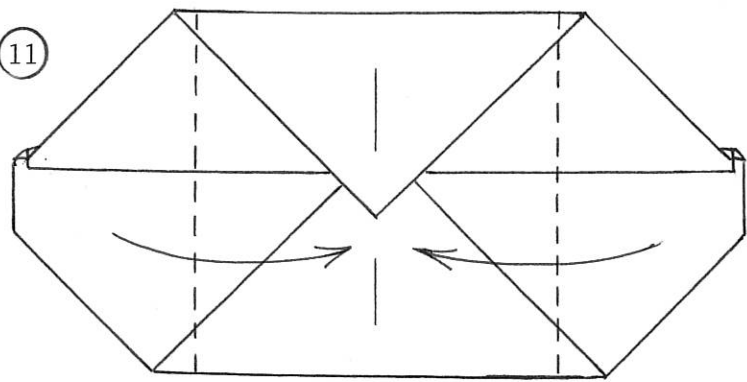

12

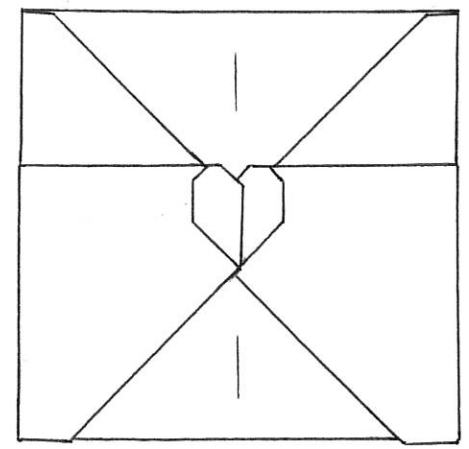

REFOLD USING EXISTING CREASES.

13

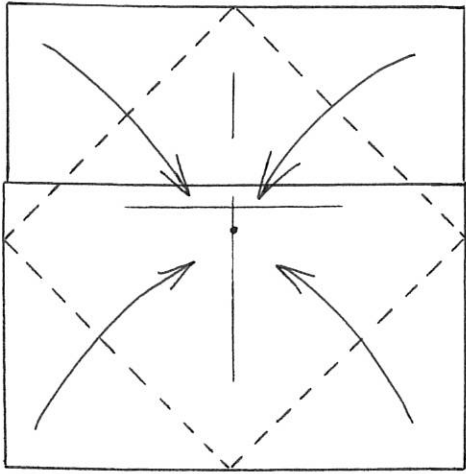

BLINTZ

14

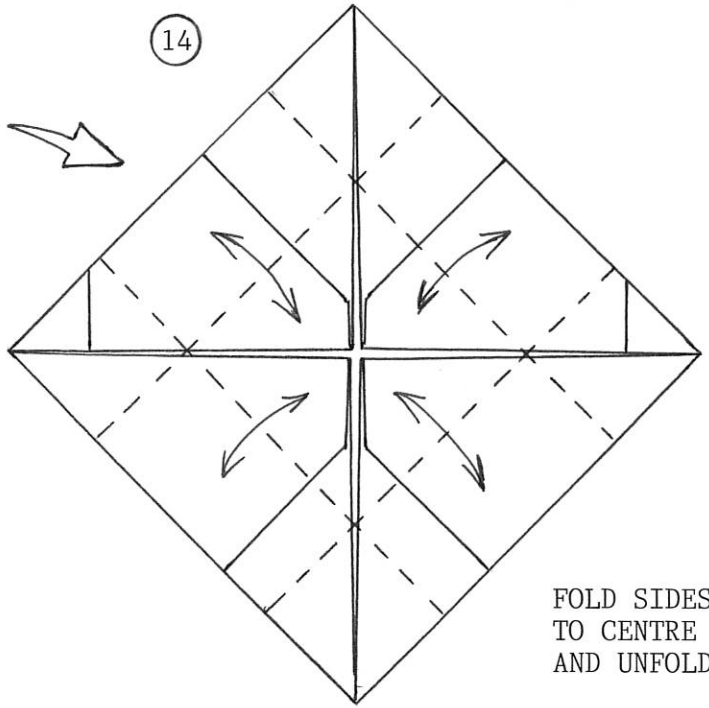

FOLD SIDES
TO CENTRE
AND UNFOLD.

15

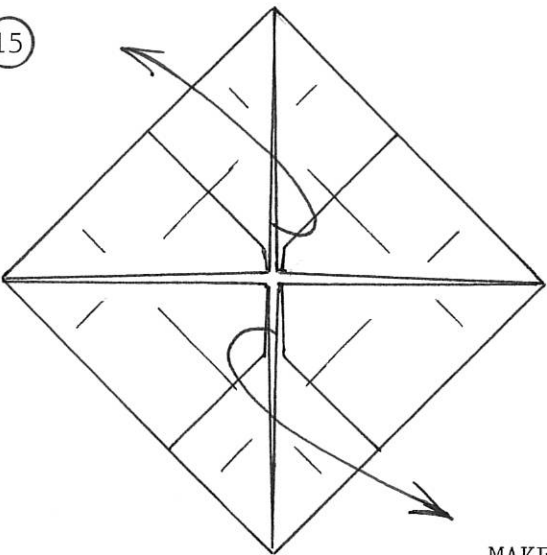

16

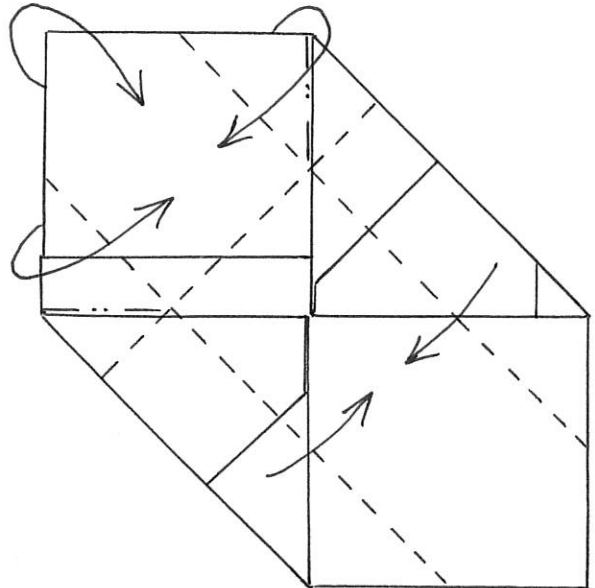

MAKE THE
TRADITIONAL
"MASU" BOX.

17

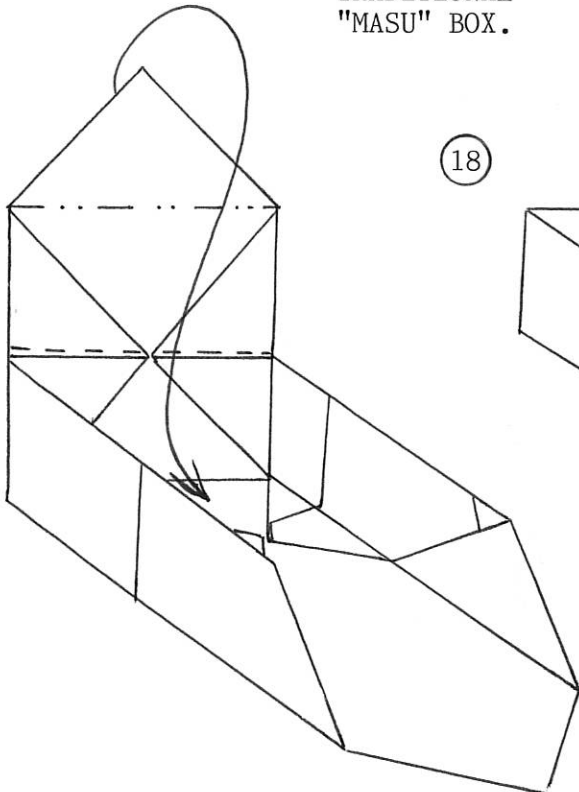

18

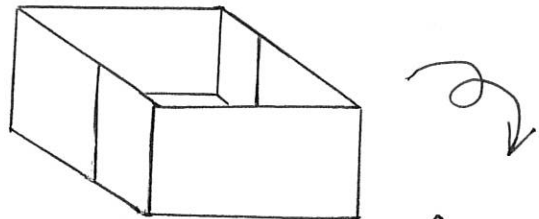

19

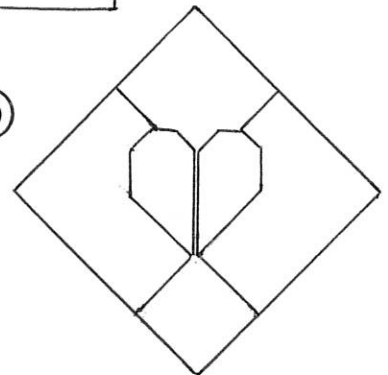

BASE

USE A SQUARE
THE SAME SIZE
AS FOR THE LID.

1

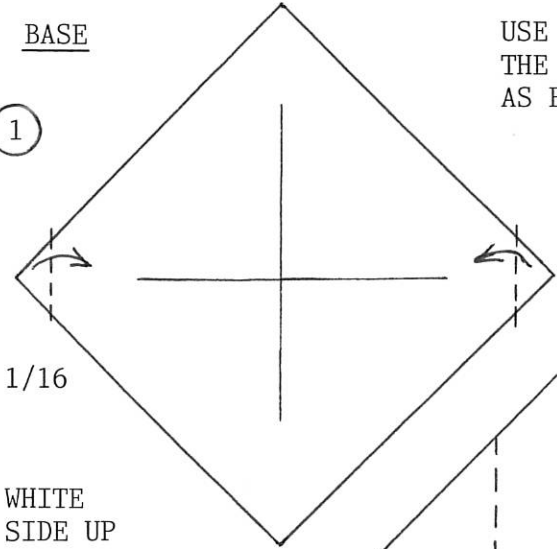

1/16

WHITE
SIDE UP

2

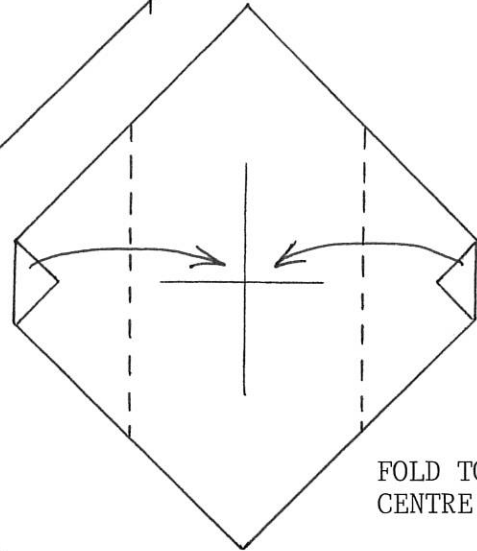

FOLD TO
CENTRE

3

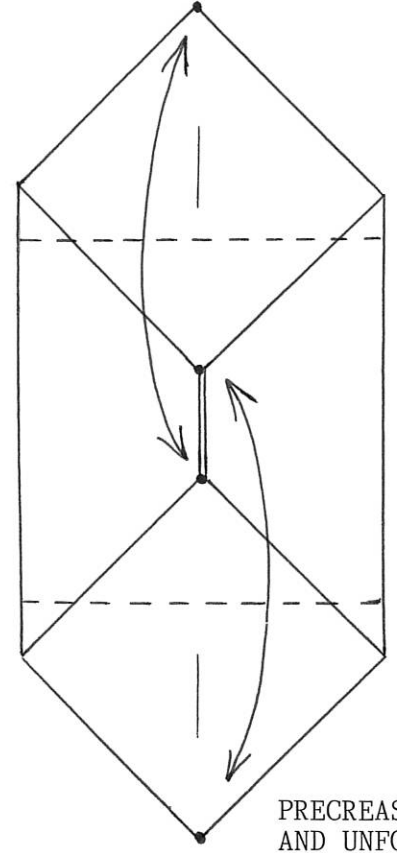

PRECREASE
AND UNFOLD
TO STEP 2

4

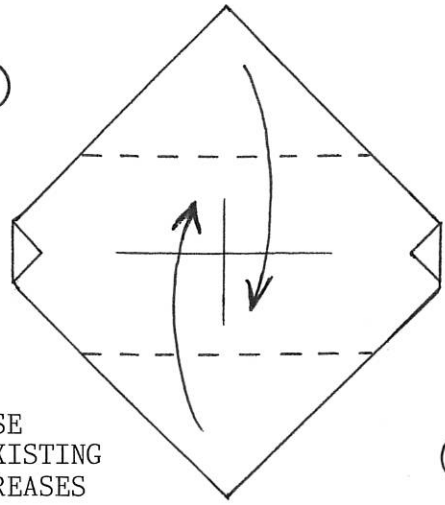

USE
EXISTING
CREASES

5

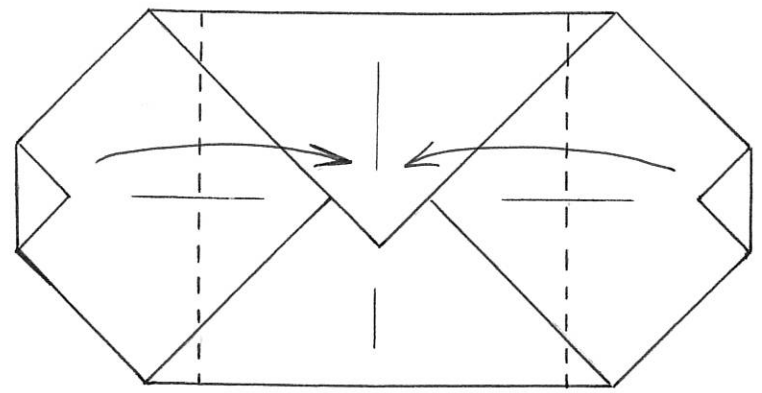

USE EXISTING CREASES

6

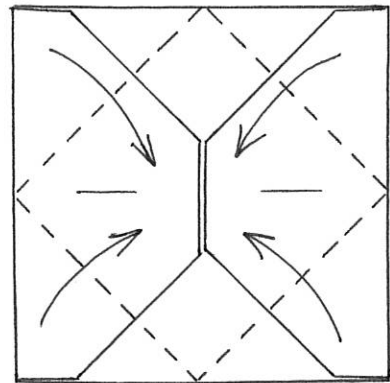

BLINTZ

7

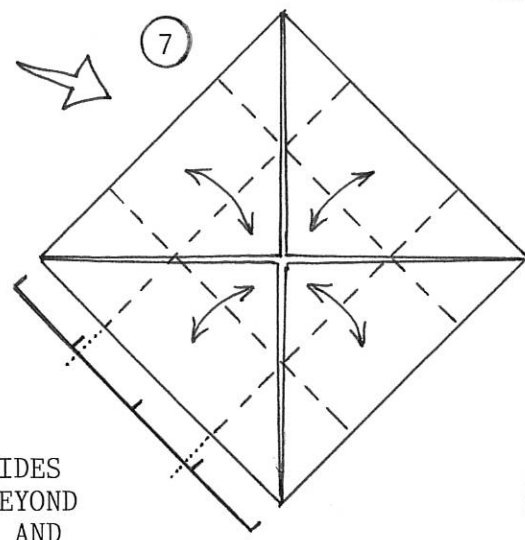

CONTINUE AS PER
STEPS 15 TO 18
OF THE LID.

FOLD ALL SIDES
SLIGHTLY BEYOND
THE CENTRE AND
UNFOLD.

8

