

MATCHBOX

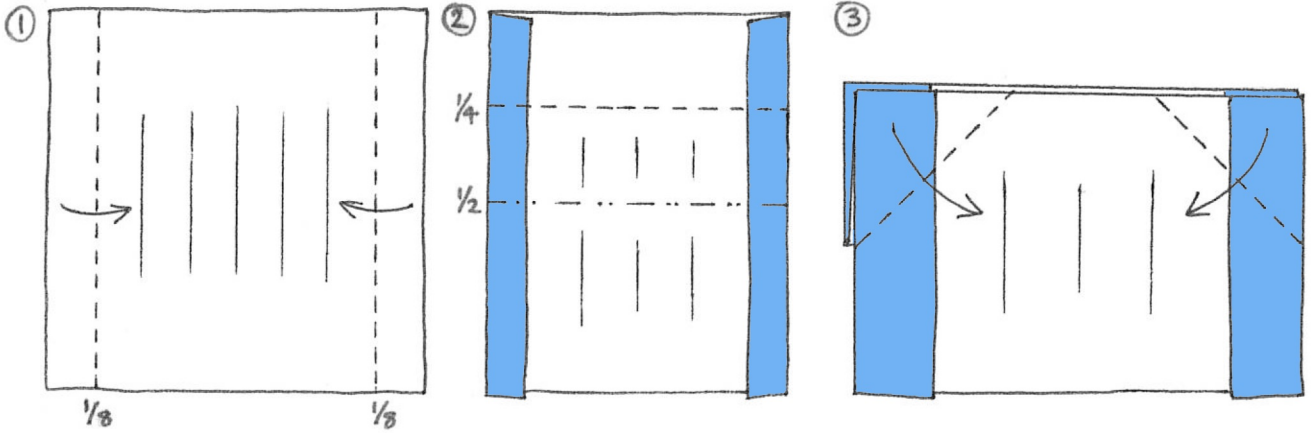

USE A LARGE, THIN SHEET OF FOIL, WHITE SIDE UP.

PLEAT

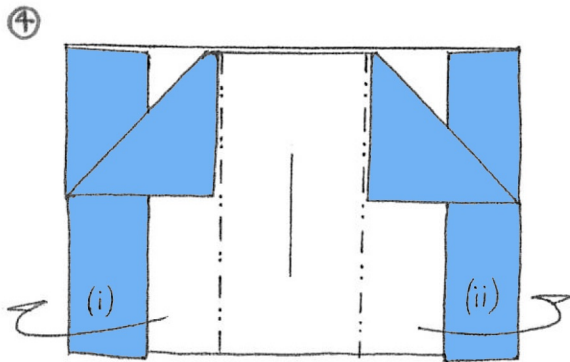

MOUNTAIN FOLDS — ONE FLAP WILL LIE ON TOP OF THE OTHER.

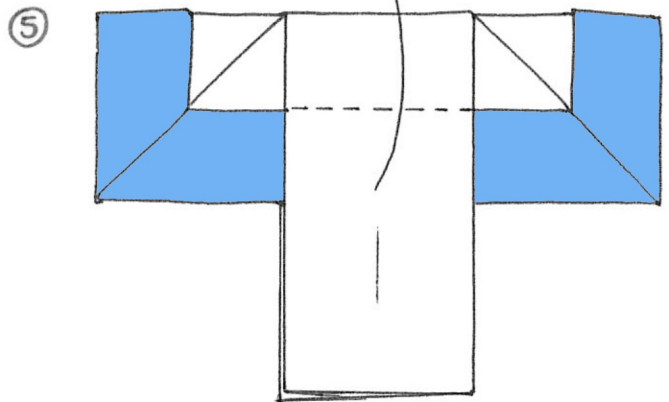

FOLD UP, RE-ARRANGING LAYERS AS NECESSARY (SEE NEXT DIAGRAM)

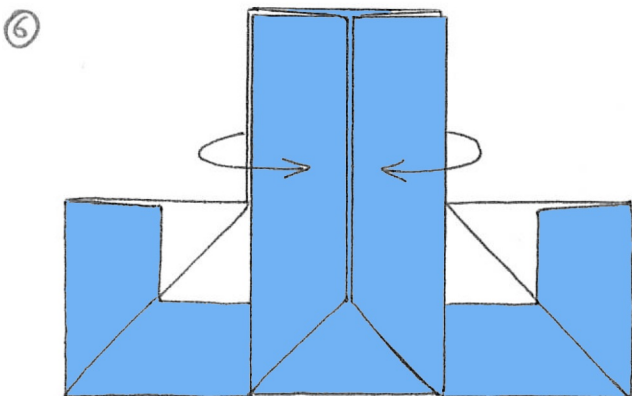

PULL OUT A SINGLE LAYER ON EACH SIDE AND WRAP AROUND

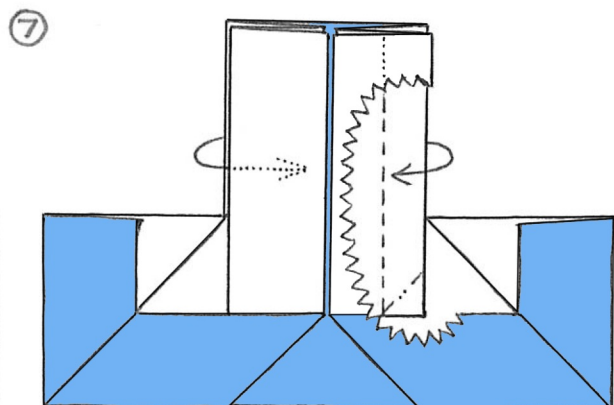

SWIVEL FOLD LOWERMOST DOUBLE LAYER ON EACH SIDE (CUT-AWAY VIEW)

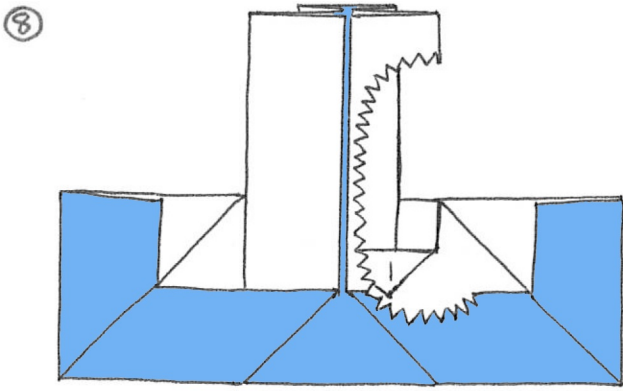

CUT-AWAY VIEW SHOWING RESULT OF STEP ⑦

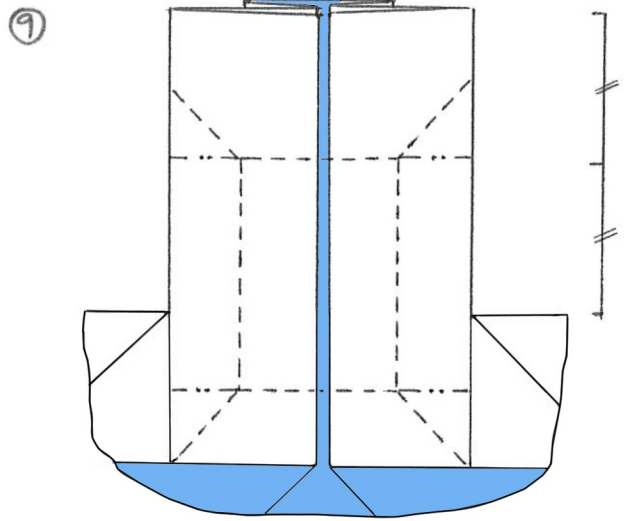

FORM THE DRAWER (MODEL BECOMES 3D)

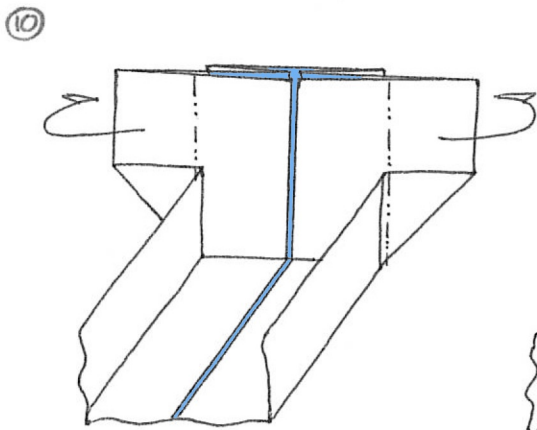

3D VIEW, DRAWER ONLY.
TUCK FLAPS INTO POCKETS

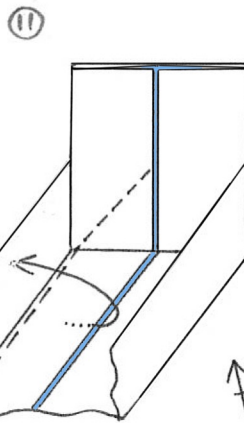

LIFT UP SINGLE LAYER
ON EACH SIDE

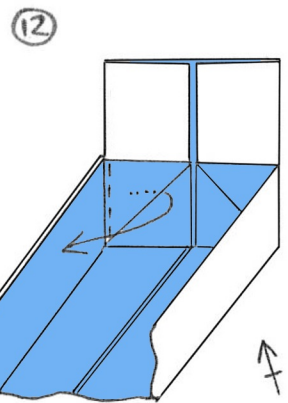

FOLD SINGLE LAYER
OVER ON EACH SIDE

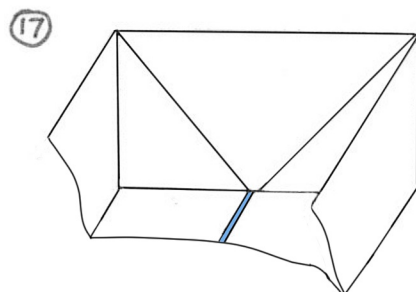
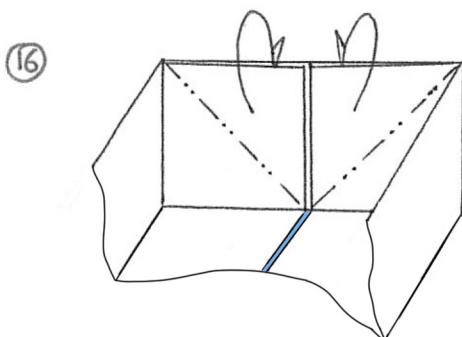
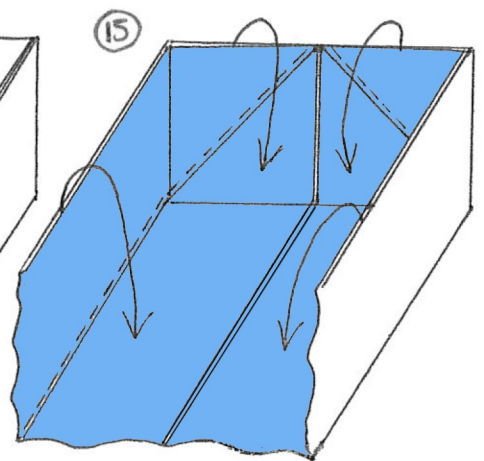
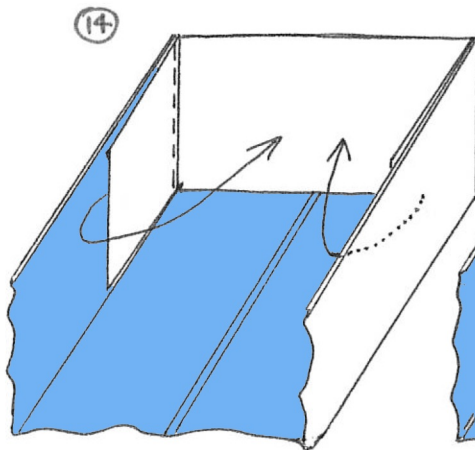
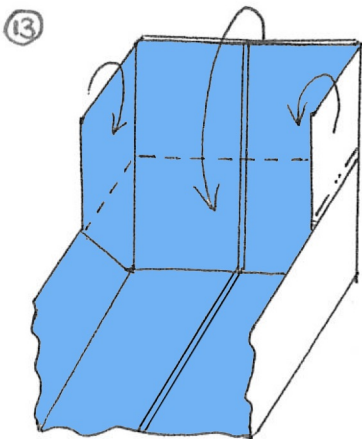

18

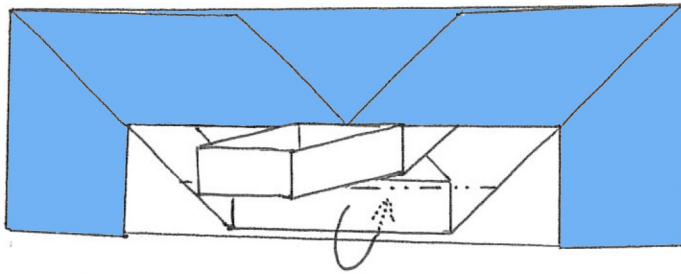

3D VIEWS SHOWING THE WHOLE MODEL. DRAWER PROTRUDES AT 90°.

MOUNTAIN FOLD LONG FLAP SO THAT THE EDGE BECOMES LEVEL WITH THE BOTTOM OF THE DRAWER.

19

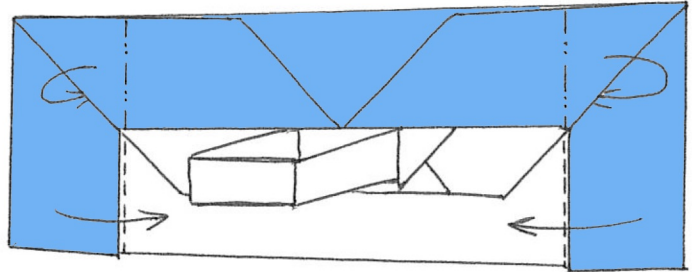

20

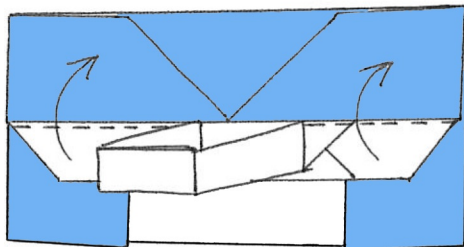

RAISE FLAP WHICH IS JOINED TO THE DRAWER SO THAT IT IS AT 90° TO THE REST OF THE COVER.

INSIDE REVERSE FOLD SIDES (OR OPEN MODEL AND VALLEY FOLD)

21

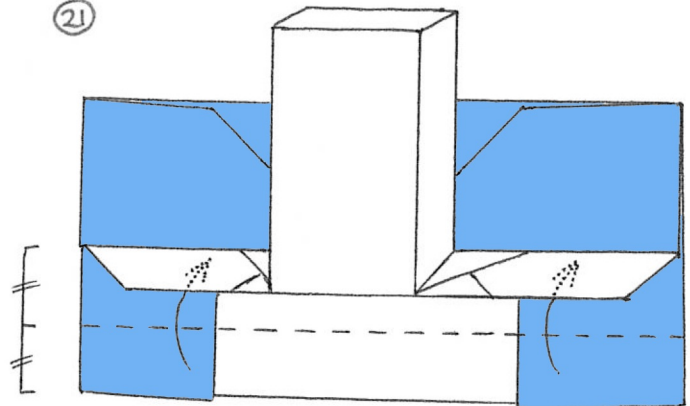

22

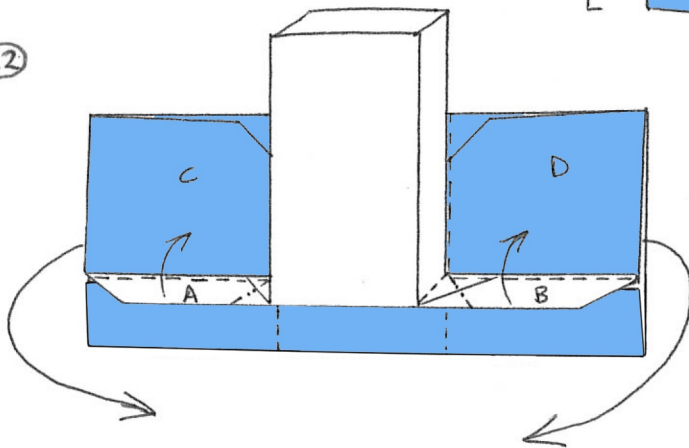

WRAP SIDES OF COVER AROUND DRAWER, FLATTENING FLAPS A AND B ONTO C AND D RESPECTIVELY. (A AND B CAN BE TUCKED INSIDE C AND D IF DESIRED). FINISH BY INTERLOCKING C AND D BENEATH THE DRAWER.

23

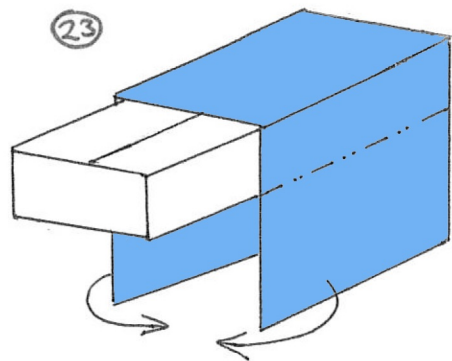

24

